

**PAPER TRAY UNIT**  
**(Machine Code: B384)**

---

# 1. OVERALL MACHINE INFORMATION

## 1.1 MECHANICAL COMPONENT LAYOUT

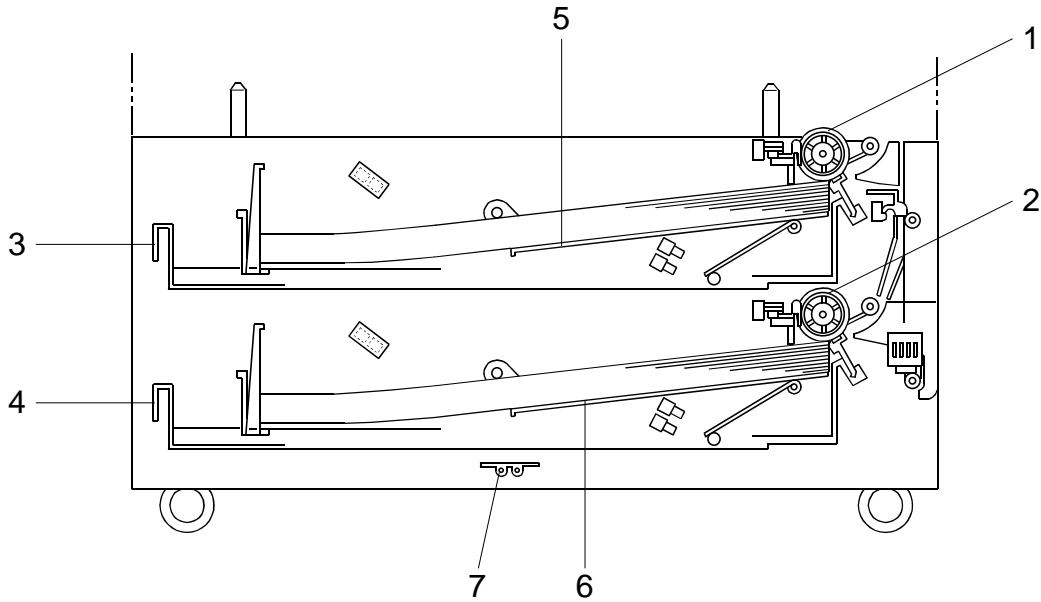

B384V101.WMF

- 1. Upper Paper Feed Roller
- 2. Lower Paper Feed Roller
- 3. Upper Tray
- 4. Lower Tray

- 5. Upper Bottom Plate
- 6. Lower Bottom Plate
- 7. Optional Tray Heater

Peripherals

## 1.2 ELECTRICAL COMPONENT LAYOUT

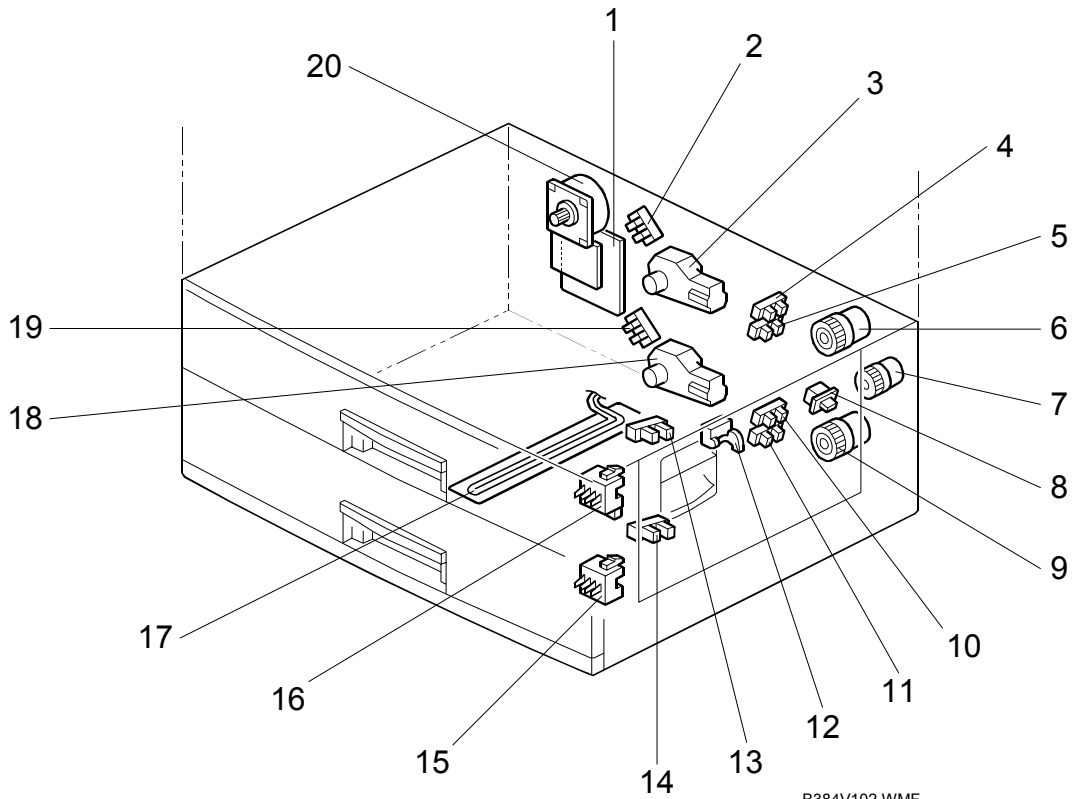

- |   |   |
|---|---|
| <ul style="list-style-type: none"> <li>1. Tray Main Board</li> <li>2. Upper Lift Sensor</li> <li>3. Upper Lift Motor</li> <li>4. Upper Paper Height 2 Sensor</li> <li>5. Upper Paper Height 1 Sensor</li> <li>6. Upper Paper Feed Clutch</li> <li>7. Relay Clutch</li> <li>8. Tray Cover Switch</li> <li>9. Lower Paper Feed Clutch</li> <li>10. Lower Paper Height 2 Sensor</li> </ul> | <ul style="list-style-type: none"> <li>11. Lower Paper Height 1 Sensor</li> <li>12. Vertical Transport Sensor</li> <li>13. Upper Paper End Sensor</li> <li>14. Lower Paper End Sensor</li> <li>15. Lower Paper Size Switch</li> <li>16. Upper Paper Size Switch</li> <li>17. Optional Tray Heater</li> <li>18. Lower Lift Motor</li> <li>19. Lower Lift Sensor</li> <li>20. Paper Feed Motor</li> </ul> |
|---|---|



### 1.3 DRIVE LAYOUT

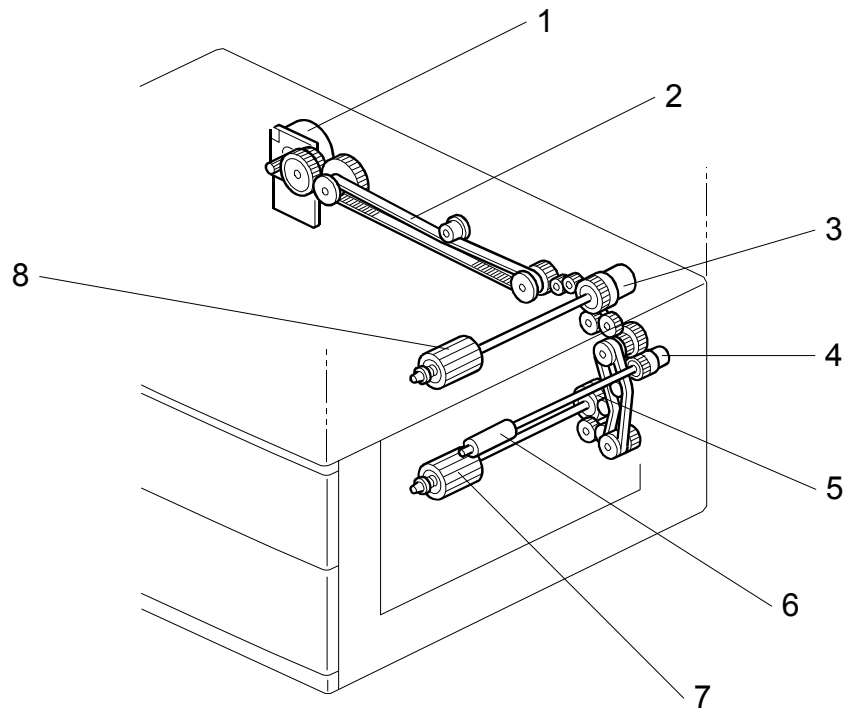

B384V103.WMF



- |                            |                            |
|----------------------------|----------------------------|
| 1. Paper Feed Motor        | 5. Lower Paper Feed Clutch |
| 2. Drive Belt              | 6. Relay Roller            |
| 3. Upper Paper Feed Clutch | 7. Lower Paper Feed Roller |
| 4. Relay Clutch            | 8. Upper Paper Feed Roller |

---

## 2. DETAILED DESCRIPTIONS

### 2.1 PAPER FEED AND SEPARATION MECHANISM

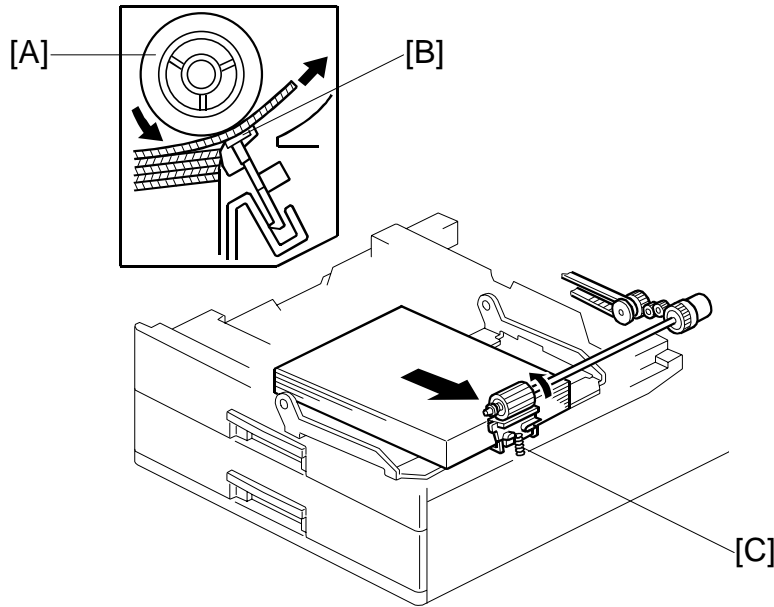

B384D104.WMF

Each paper tray holds 500 sheets. The paper feed roller [A] drives the top sheet of paper from the paper tray to the copier/printer. The friction pad [B] allows only one sheet to feed at a time. The friction pad applies pressure to the feed roller with a spring [C].

## 2.2 PAPER LIFT MECHANISM

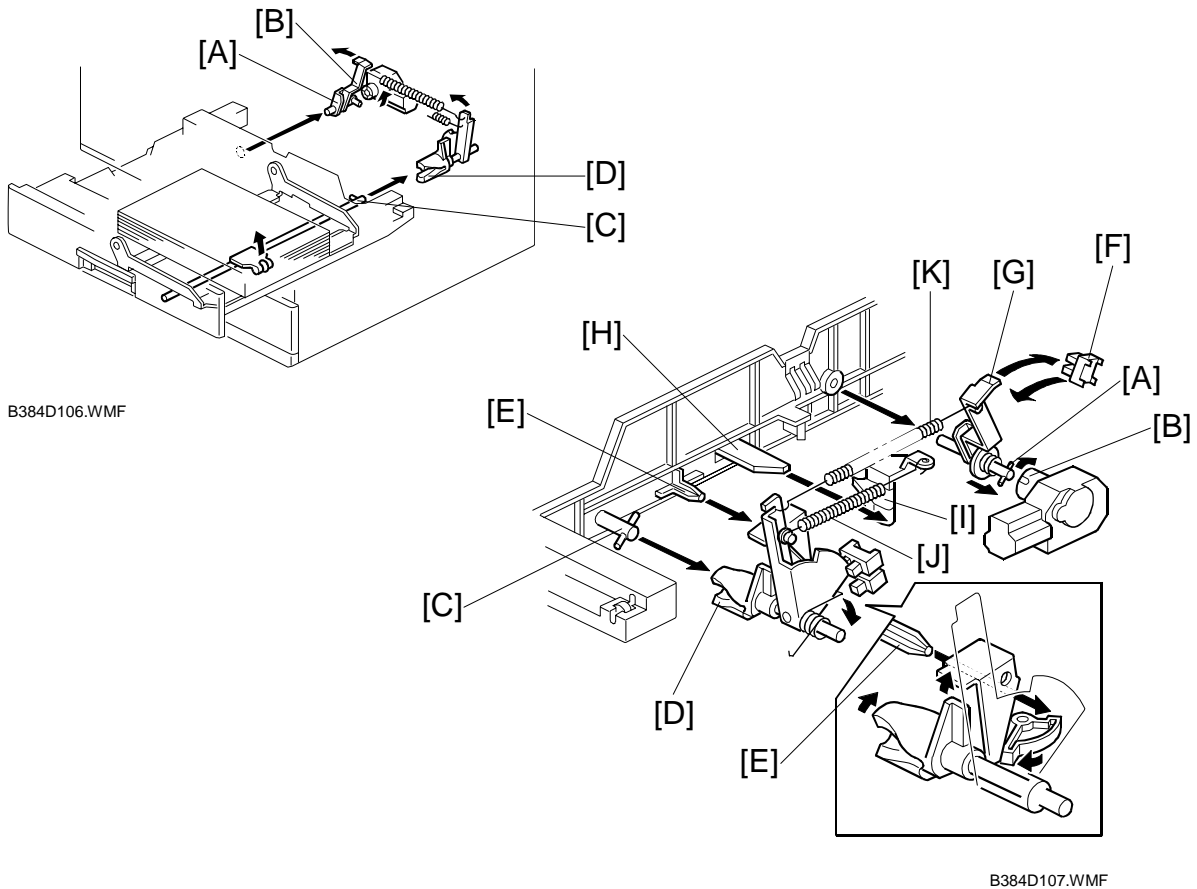

The paper size switch detects when the tray is pushed in.

When the paper tray is pushed into the machine, the pin [A] for the lift motor pressure shaft engages the lift motor coupling [B] and the pin [C] for the bottom plate lift shaft in the tray engages the bottom plate pressure lever coupling [D]. The pin [E] on the rear of the tray pushes the lock lever so that the lift motor can lift the bottom plate pressure lever.

The lift motor turns on, and turns clockwise as viewed on the lower diagram. The main pressure spring [K] pulls the bottom plate pressure lever, and this lifts the tray bottom plate.

When the top of the stack touches the feed roller, the motor cannot pull up the plate any more, so it pulls the actuator [G] into the lift sensor [F].

The pressure of the feed roller on the paper is now too high, so the lift motor reverses to reduce this pressure. It reverses for 300 ms or 600 ms, depending on the paper size. For smaller paper, it reverses the larger amount (600 ms) to reduce the pressure more.



The lift motor reverse timing can be adjusted with SP mode, to change the pressure from the main pressure spring.

- SP1-908-1 (1st tray), 1-908-2 (2nd tray)
- Default: 0
- Increase the pressure: +1, +2
- Decrease the pressure: -1, -2

If the pressure is too strong, the sheet of paper may not be fed smoothly, and if it is too weak, more than one sheet of paper may be fed at a time.

For A4-LEF, A3-SEF, and B4-SEF paper, a projection [H] on the side fence engages the secondary pressure spring [J] through a lever [I]. Then, the secondary pressure spring [J] applies paper feed pressure in addition to the main pressure spring [K], to ensure that extra pressure is applied to wider paper.

When the paper tray is pulled out, the pins [A, C] disengage from the couplings [B, D], and the bottom plate drops. To make it easier to push the tray in, the lift motor rotates backwards 1.7 seconds to return the bottom plate pressure lever coupling [D] to the original position.

## 2.3 PAPER END DETECTION

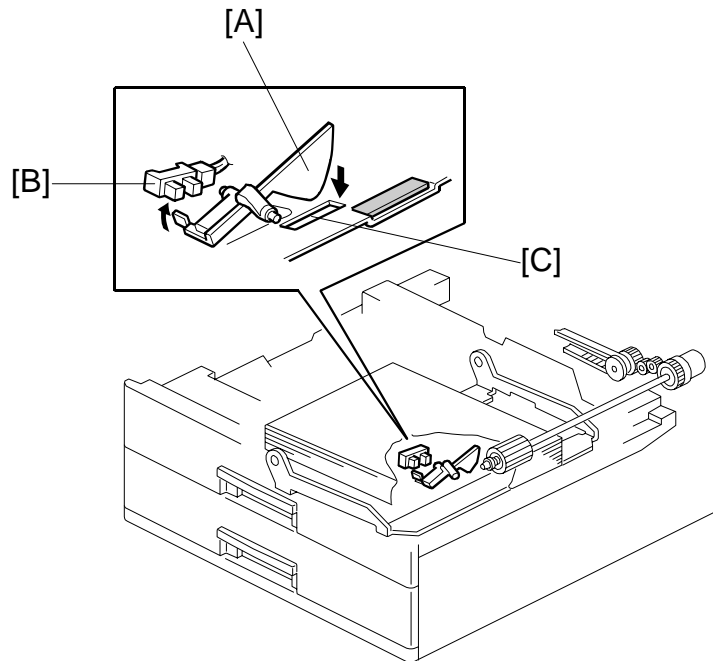

B384D105.WMF

If there is some paper in the paper tray, the paper stack raises the paper end feeler [A] and the paper end sensor [B] is deactivated.

When the paper tray runs out of paper, the paper end feeler drops into the cutout [C] in the tray bottom plate and the paper end sensor is activated.

When the paper tray is drawn out with no paper in the tray, the shape of the paper end feeler causes it to lift up.



## 2.4 PAPER HEIGHT DETECTION

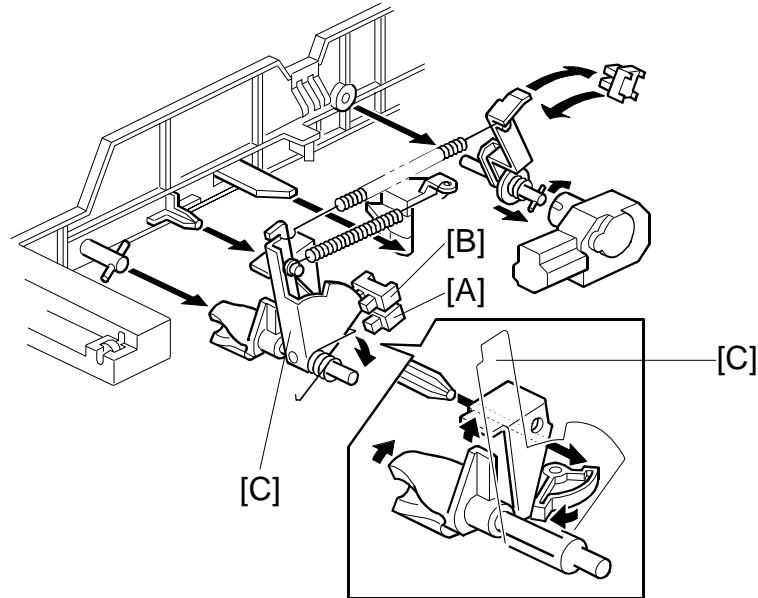

B384D107.WMF

The amount of paper in the tray is detected by the combination of on/off signals from two paper height sensors [A] and [B].

When the amount of paper decreases, the bottom plate pressure lever [C] moves the actuator up.

The following combination of sensor signals is sent to the copier/printer.

Amount of Paper	Paper Height Sensor 1	Paper Height Sensor 2
Near End	OFF	ON
30%	ON	ON
70%	ON	OFF
100%	OFF	OFF

When the tray contains paper of a small width, the paper feed pressure may become too low when the thickness of the remaining stack of paper has decreased. The lift motor rotates forward 300 ms after the sensor detects a certain amount of paper remaining in the tray to increase paper feed pressure, simulating the pressure generated by a full tray.

# PAPER SIZE DETECTION

Size	SW	1	2	3	4
A3, F (8 1/2" x 13")		○	○	○	○
A4 short-edge		●	●	○	○
A4 long-edge		●	●	○	●
A5 long-edge 11" x 17"		○	○	●	●
B4, 8 1/2" x 14"		●	○	●	○
B5 long-edge, 8 1/2" x 11"		●	○	○	○
B5 short-edge, 11" x 8 1/2"		○	●	●	●
* (Asterisk)		○	●	○	●

○: ON (Pushed)  
●: OFF (Not pushed)

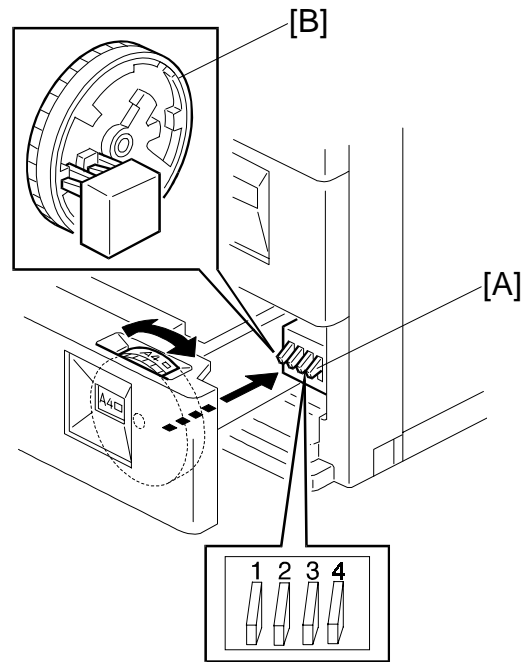

B384D108.WMF

There are four paper size microswitches [A] on the front right plate of the paper tray unit. The switches are actuated by a paper size actuator [B] behind the paper size indicator plate, which is on the front right of the tray.

Each paper size has its own actuator, with a unique combination of notches. To determine which size has been installed, the CPU reads which microswitches the actuator has switched off.

The CPU disables paper feed from a tray if the paper size cannot be detected. If the paper size actuator is broken, or if there is no tray installed, the Add Paper indicator will light.

When the paper size actuator is at the "\*" mark, the paper tray can be set up to accommodate one of a wider range of paper sizes by using user tools. If the paper size for this position is changed without changing the user tool setting, a paper jam will result.

## 2.5 SIDE AND END FENCES

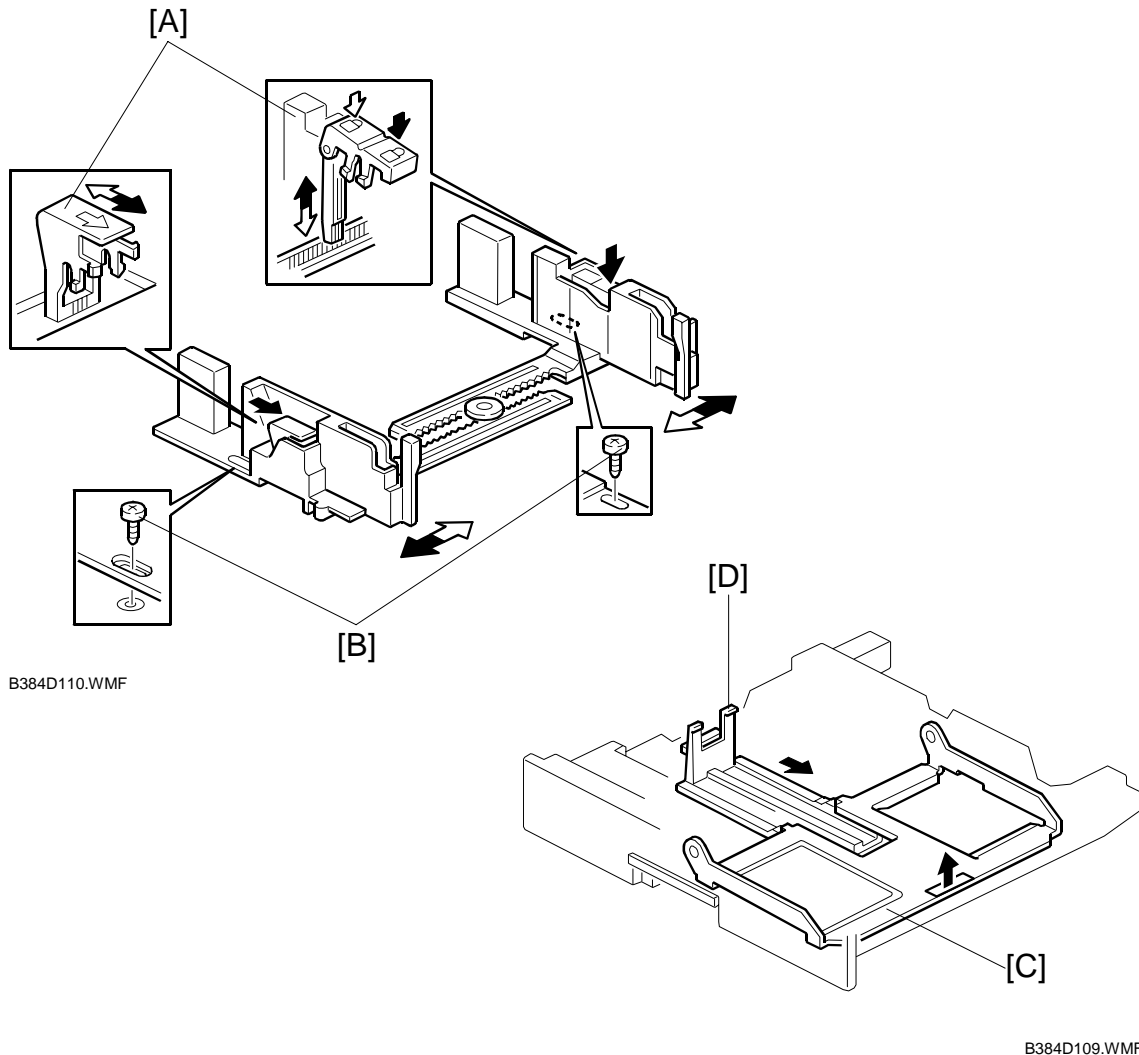

### **Side Fences**

If the tray is full of paper and it is pushed in strongly, the fences may deform or bend. This may cause the paper to skew or the side-to-side registration to be incorrect. To correct this, each side fence has a stopper [A] attached to it. Each side fence can be secured with a screw [B], for customers who do not want to change the paper size.

### **End Fence**

As the amount of paper in the tray decreases, the bottom plate [C] lifts up gradually. The end fence [D] is connected to the bottom plate. When the tray bottom plate rises, the end fence moves forward and pushes the back of the paper stack to keep it squared up.

---

## 3. REPLACEMENT AND ADJUSTMENT

### 3.1 FEED ROLLER REPLACEMENT

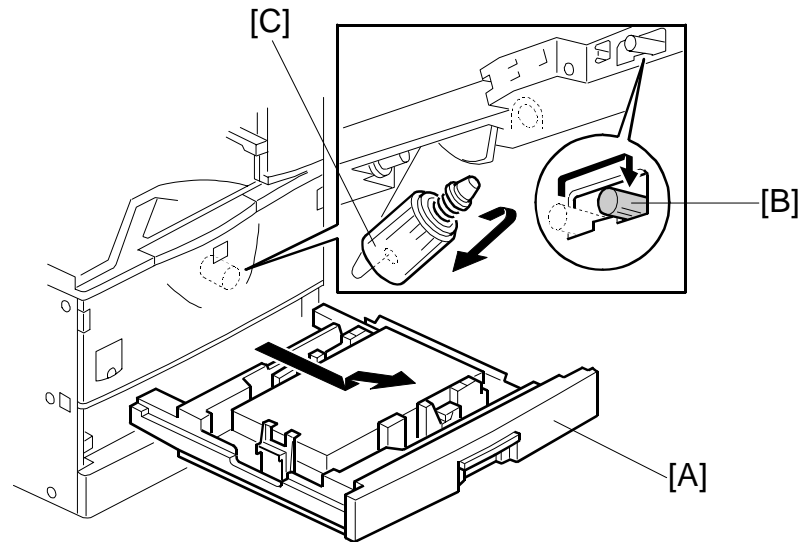

B384R723.WMF

1. [A] Paper tray
2. Move the release lever [B] to the front.
3. Pull the feed roller [C] to the operation side and remove it.

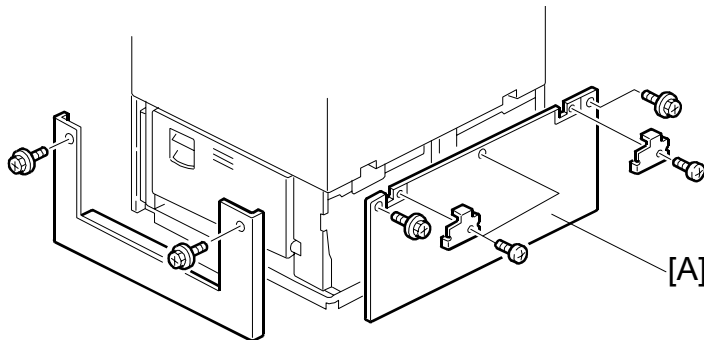

B384R101.WMF

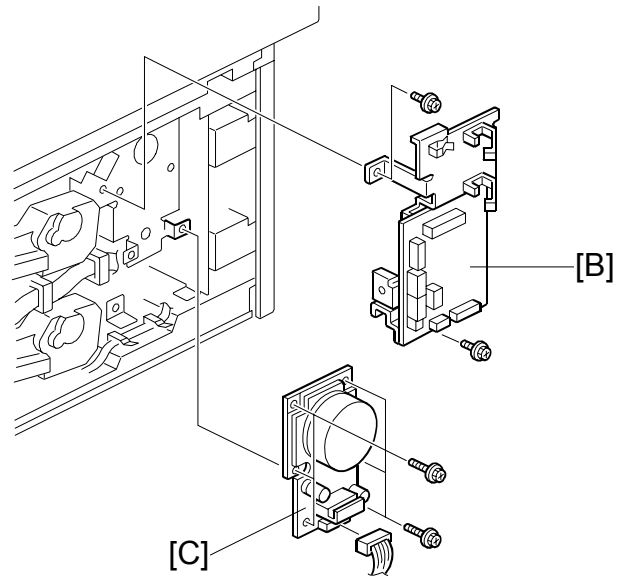

B384R103.WMF

## 3.2 TRAY MAIN BOARD REPLACEMENT

1. [A] Rear cover (⚙ x 5)
2. [B] Tray main board (⚙ x 4, 📡 x 8)

## 3.3 PAPER FEED MOTOR REPLACEMENT

1. Rear cover (⚙ x 5)
2. Disconnect 8 connectors from the tray main board [B].
3. Tray main board with the bracket (⚙ x 2)
4. [C] Paper feed motor (⚙ x 6, 📡 x 1)

### 3.4 RELAY CLUTCH REPLACEMENT

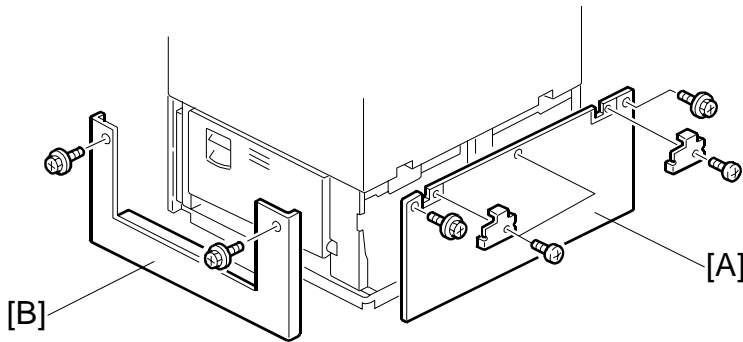

B384R101.WMF

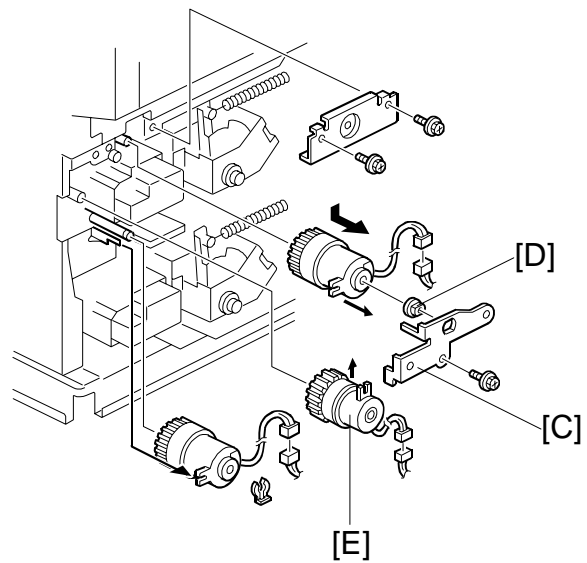

B384R102.WMF

1. [A] Rear cover (🔩 x 5)
2. [B] Right cover (🔩 x 2)
3. [C] Stopper bracket (🔩 x 1)
4. [D] Bushing
5. [E] Relay clutch (🔩 x 1)

### 3.5 UPPER PAPER FEED CLUTCH REPLACEMENT

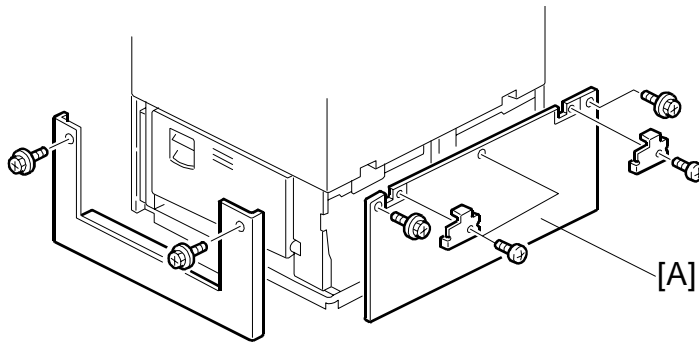

B384R101.WMF

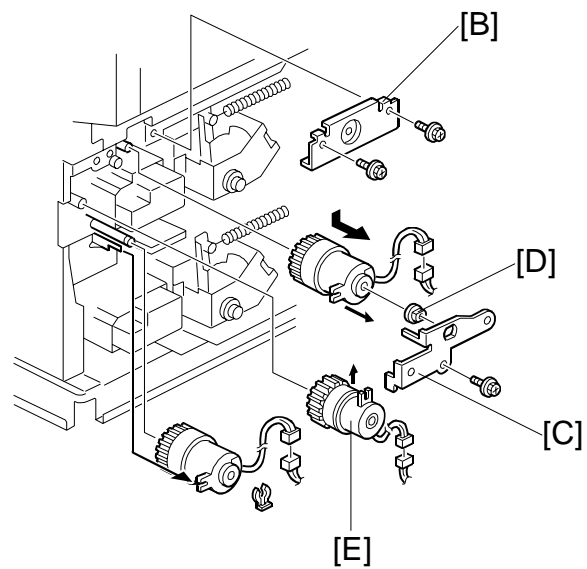

B384R102.WMF

1. [A] Rear cover (🔩 x 5)
2. [B] Bracket (🔩 x 2)
3. [C] Stopper bracket (🔩 x 2)
4. [D] Bushing
5. [E] Upper paper feed clutch (🔩 x 1)

### 3.6 LOWER PAPER FEED CLUTCH REPLACEMENT

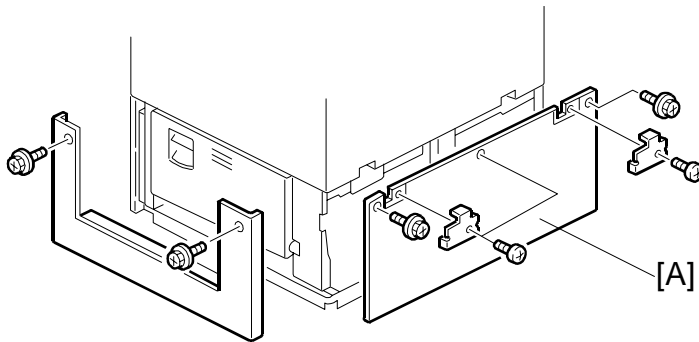

B384R101.WMF

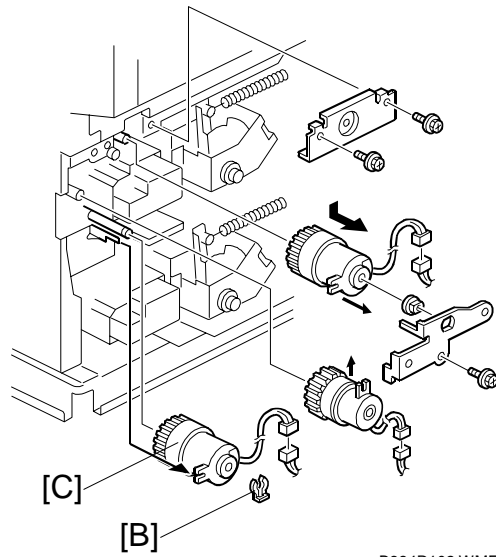

B384R102.WMF

1. [A] Rear cover (⌀ x 5)
2. [B] Snap ring
3. [C] Lower paper feed clutch



### 3.7 LIFT MOTOR REPLACEMENT

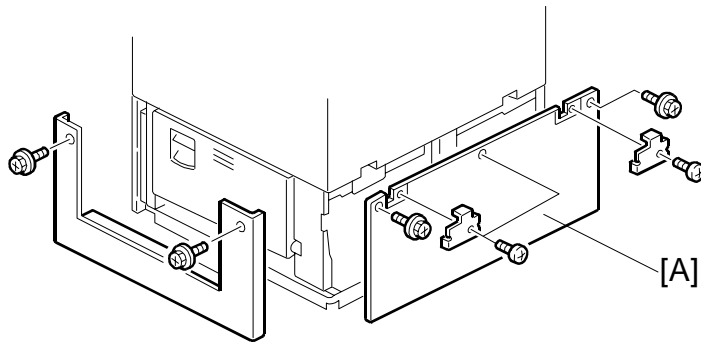

B384R101.WMF

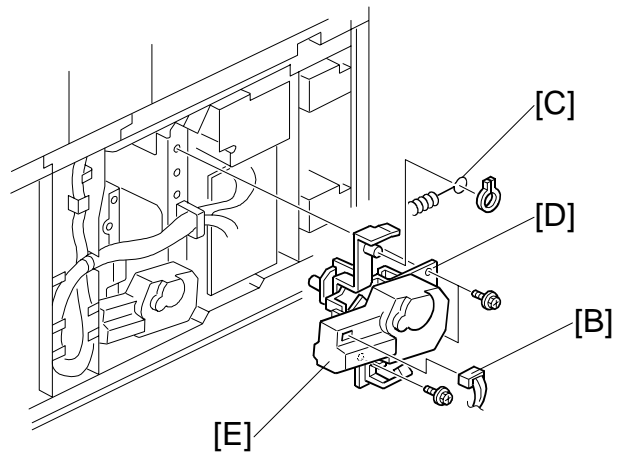

B384R104.WMF

1. Pull out the paper tray.
2. [A] Rear cover (⚙ x 5)
3. [B] 2P connector
4. [C] Spring
5. [D] Lift motor unit (⚙ x 3)
6. [E] Lift motor (⚙ x 3)

### 3.8 PAPER END SENSOR REPLACEMENT

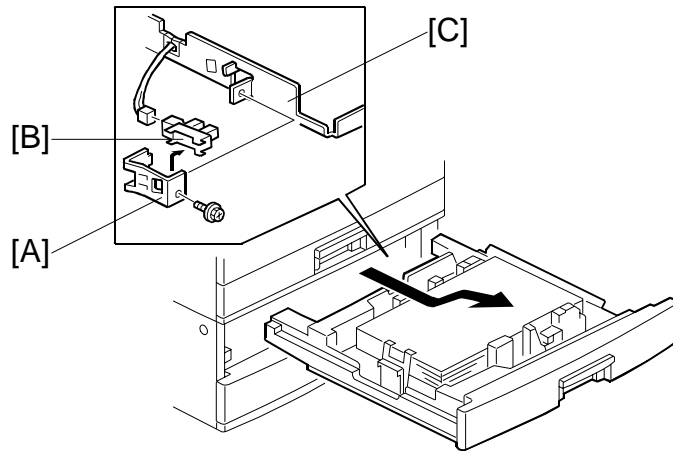

B384R106.WMF

1. Paper tray
2. [A] Paper end sensor bracket (⚙️ x 1, 📏 x 1)
3. [B] Paper end sensor

**NOTE:** After replacing the sensor, pull the sensor cable towards the right side of the frame [C] so that it does not touch the paper in the tray.

### 3.9 VERTICAL TRANSPORT SENSOR REPLACEMENT

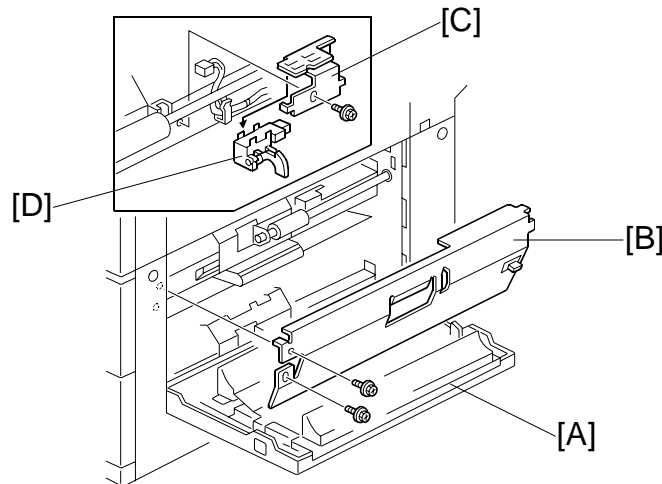

B384R105.WMF

1. Open the right door [A].
2. [B] Right guide plate (⚙️ x 2)
3. [C] Vertical transport sensor bracket (⚙️ x 1, 📏 x 1)
4. [D] Vertical transport sensor

### 3.10 PAPER SIZE SWITCH REPLACEMENT

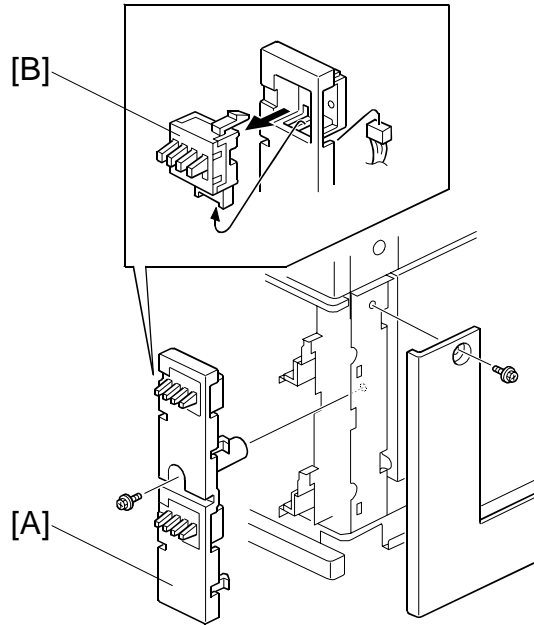

B384R108.WMF

1. Upper and lower paper trays
2. [A] Inner cover (🔩 x 2)
3. [B] Paper size switch (🔑 x 1)

# ELECTRICAL COMPONENT LAYOUT (B384)

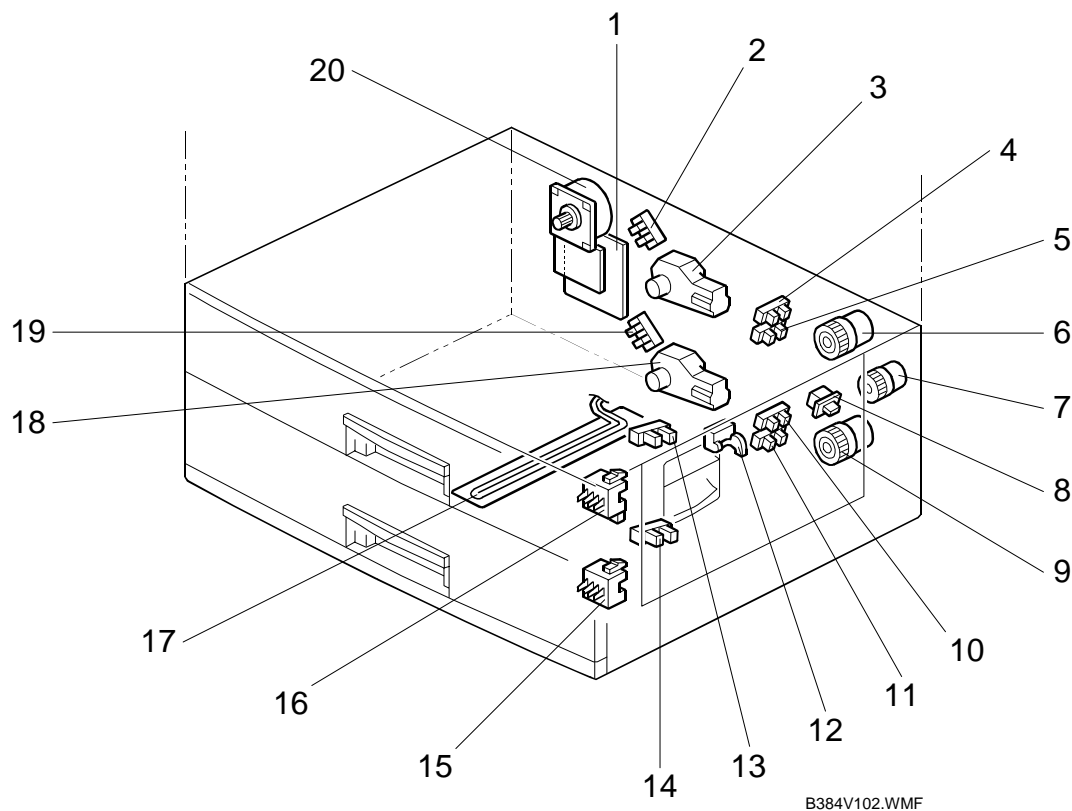

B384V102.WMF

Symbol	Name	Index No.	P-to-P
<b>Motors</b>			
M1	Paper Feed	20	E12
M2	Lower Lift	18	E13
M3	Upper Lift	3	E13
<b>Sensors</b>			
S1	Lower Paper Height 2	10	E8
S2	Lower Paper Height 1	11	E9
S3	Upper Paper Height 2	4	E9
S4	Upper Paper Height 1	5	E9
S5	Vertical Transport	12	E10
S6	Lower Paper End	14	E10
S7	Upper Paper End	13	E11
S8	Lower Lift	19	E13
S9	Upper Lift	2	E13
<b>Switches</b>			
SW1	Upper Paper Size	16	E9
SW2	Lower Paper Size	15	E10
SW3	Tray Cover	8	E11
<b>Magnetic Clutches</b>			
MC1	Upper Paper Feed	6	E11
MC2	Relay	7	E11
MC3	Lower Paper Feed	9	E12
<b>PCBs</b>			
PCB1	Tray Main	1	D9-13
<b>Others</b>			
H1	Optional Tray Heater	17	E14